

Spectral Detection of Nonlinear RF Interactions in Biological Preparations Exposed to RF Energy

Quirino Balzano and Christopher C. Davis

Department of Electrical and Computer Engineering

RATIONALE

- Cellular systems have been reported to apparently demodulate an RF carrier and exhibit low frequency bioeffects
- If this occurs then cellular response is nonlinear
- This nonlinearity should also be manifest through harmonic mixing

INSTRUMENTATION

LAYOUT OF EQUIPMENT

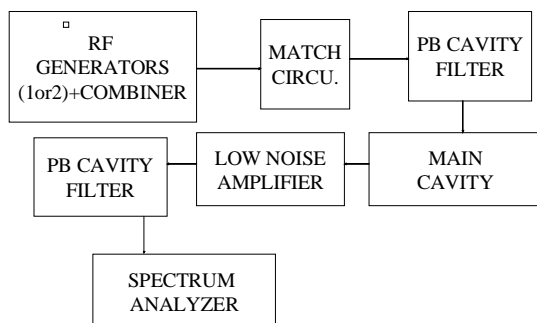

- Stable and clean RF generators
- Cavity pass band filters (2 or 3)
- 30dB low noise amplifier and spectrum analyzer
- Main cavity with bio-preparation
- Nonlinear device for calibration
- Linear materials for bio-support structure
- Combiner plus matching circulator

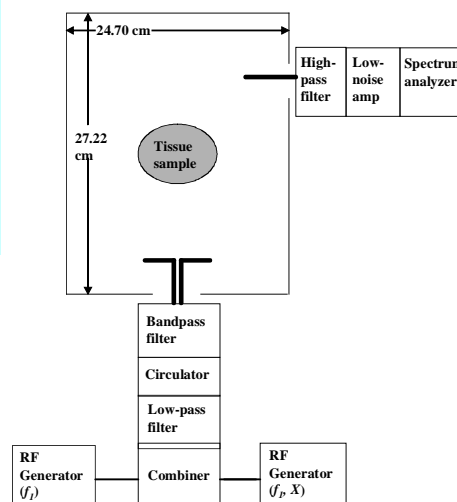

EXPECTED OPERATING PARAMETERS

- Commercial cavity filters (2 or 3)
- $Q \sim 500 - 1000..$
- Main cavity $Q = 30 - 40 \times 10^3$ (unloaded)
- Small bio-sample $V \ll 1 \text{ cm}^3$ to keep main cavity tuned with high Q
- Loaded main cavity $Q \sim 4 \times 10^3$
- Generator frequency 900 MHz
- 10 mW power

EXPECTED SENSITIVITY

- At 1800 MHz $10 - 30 \mu\text{V} / 10 \text{ dBm}$ or $10 - 100$ photons/cell/second with 10^6 cells in the bio-sample
- The cavity is detuned by the loss in the biological preparation
- Maximum sensitivity is a balance between the sample size and the cavity Q factor

DIFFICULT TASKS

- Proper calibration of nonlinearity
- Keeping nonlinearities below detectable levels with no bio-sample
- Avoiding contact oxidation
- Removable cavity top or bottom without compromising the Q factor
- Correct location of the bio-sample in the cavity for maximum Q at 1800MHz

This research is sponsored by MTHR (Mobile Telephone Health Research London, UK)