

Long range 1.2Gbps Optical Link

Free space optics (FSO) is a viable solution to the Last Mile Problem. In urban areas, optical fiber can cost as much as \$1 Million per mile to install. With an available line-of-sight, FSO can offer high bandwidth performance at a fraction of the cost of fiber. In our group, we integrate custom Compound Parabolic Concentrators and off-the-shelf fiber-coupled components in the design of compact transceiver units, probe polarization-based transmission schemes, and assess link performance.

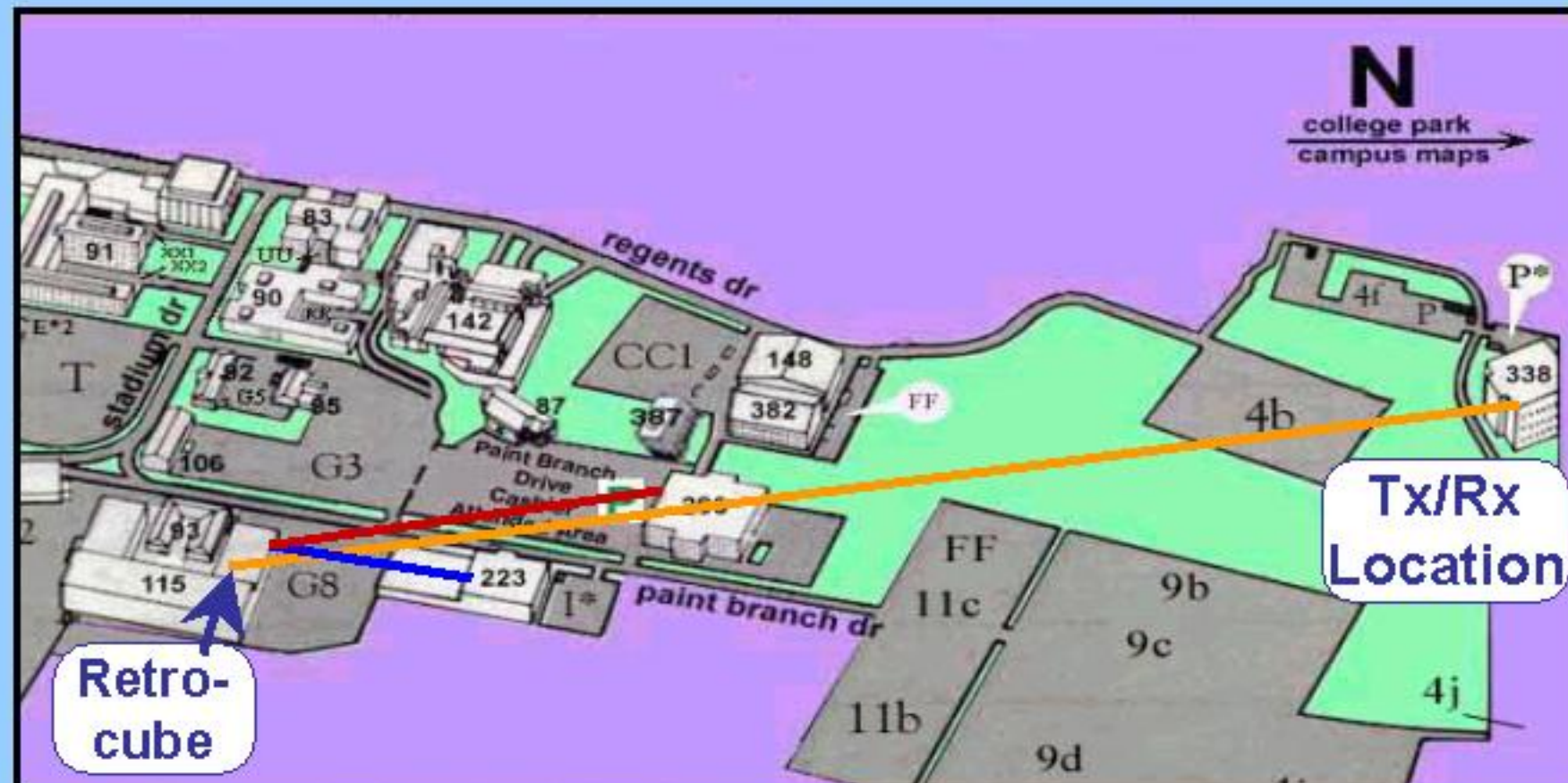

Test ranges set up on University of Maryland campus. Orange line indicates long range test link of 2km.

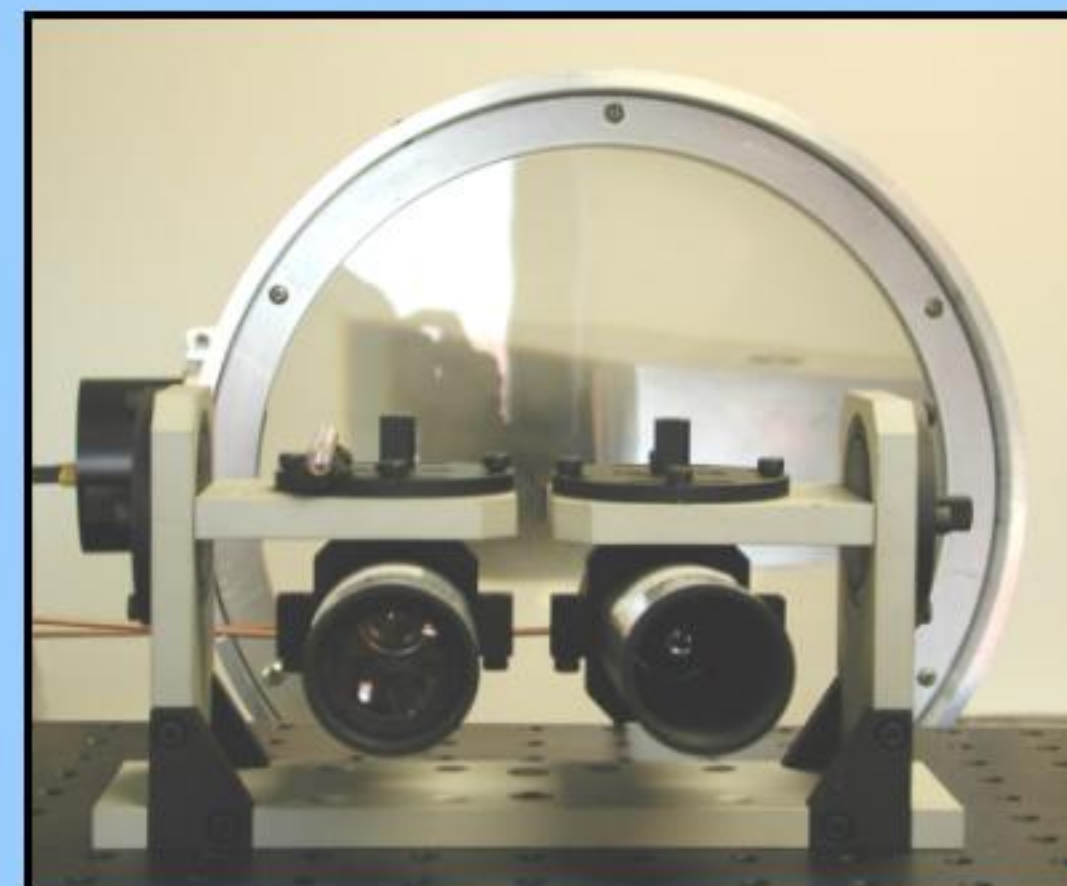

Performance comparison of FSO transceivers with different aperture diameters.

Eye Diagram at 1 Gbps

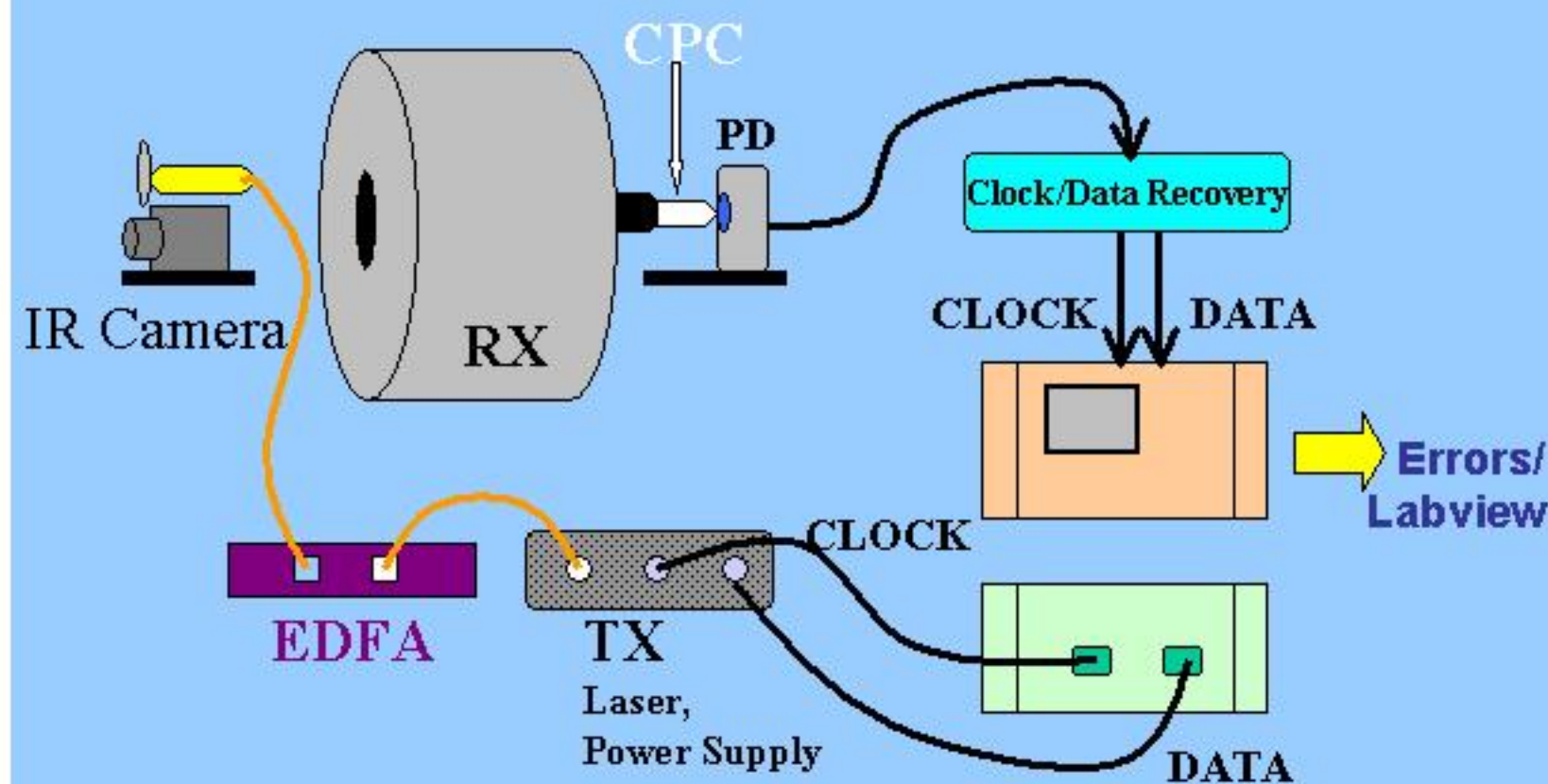
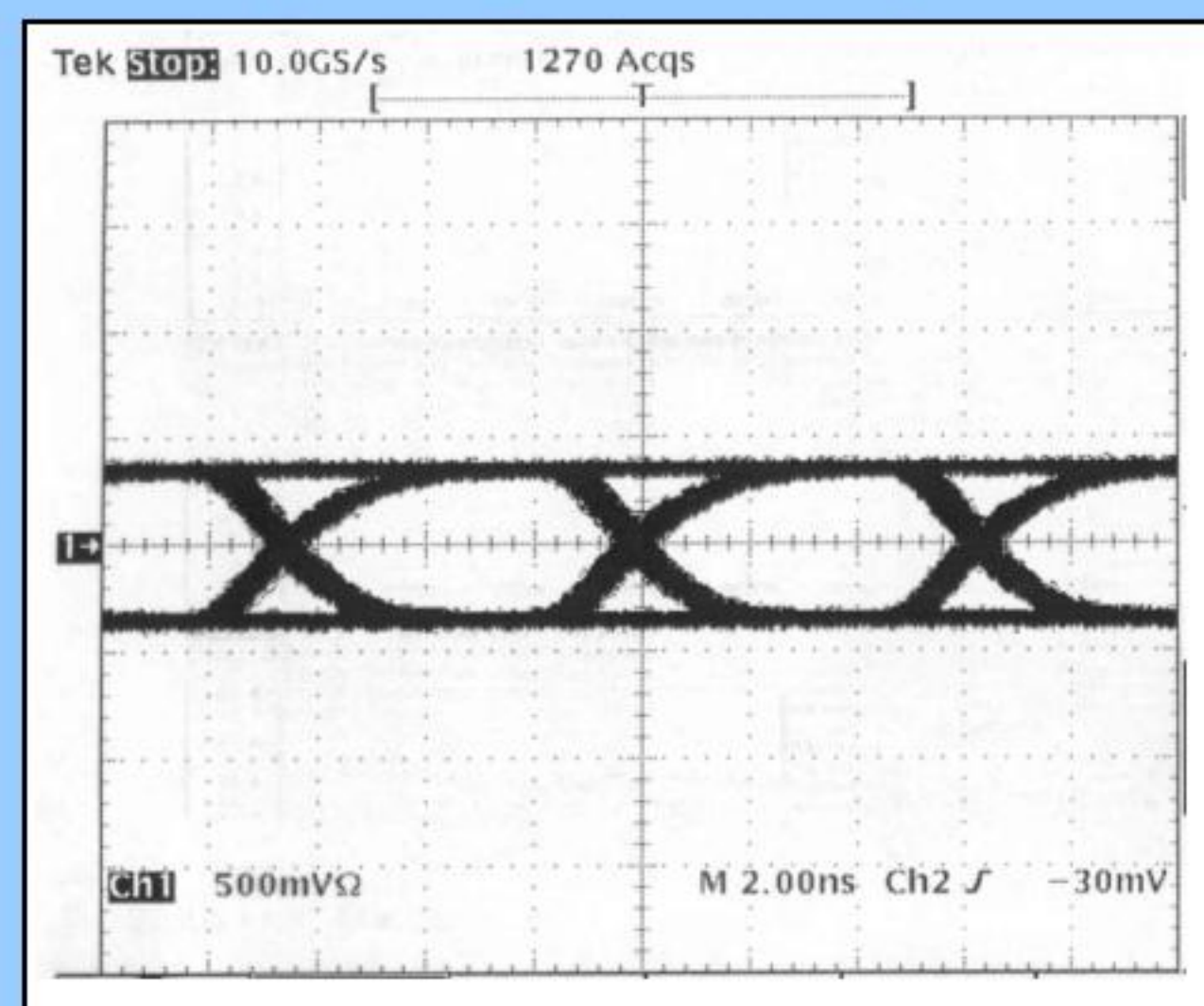

Experimental Setup of high data rate link

Aperture Averaging of Optical Scintillations

Purpose: Determine a design parameter for the receiver aperture in a free space optical link, given system specifications such as link range and operating wavelength.

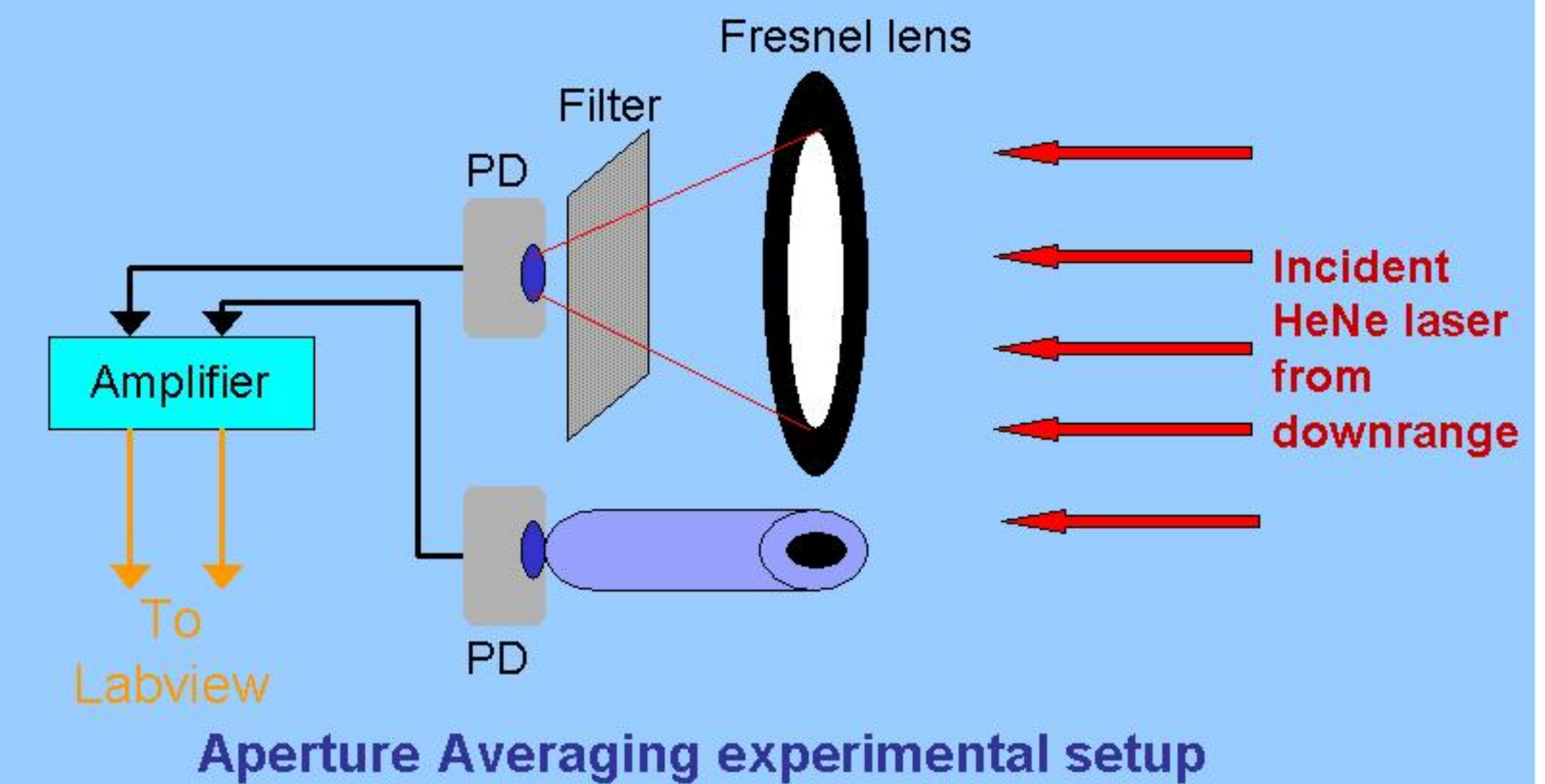

Aperture Averaging experimental setup

APERTURE AVERAGING

